

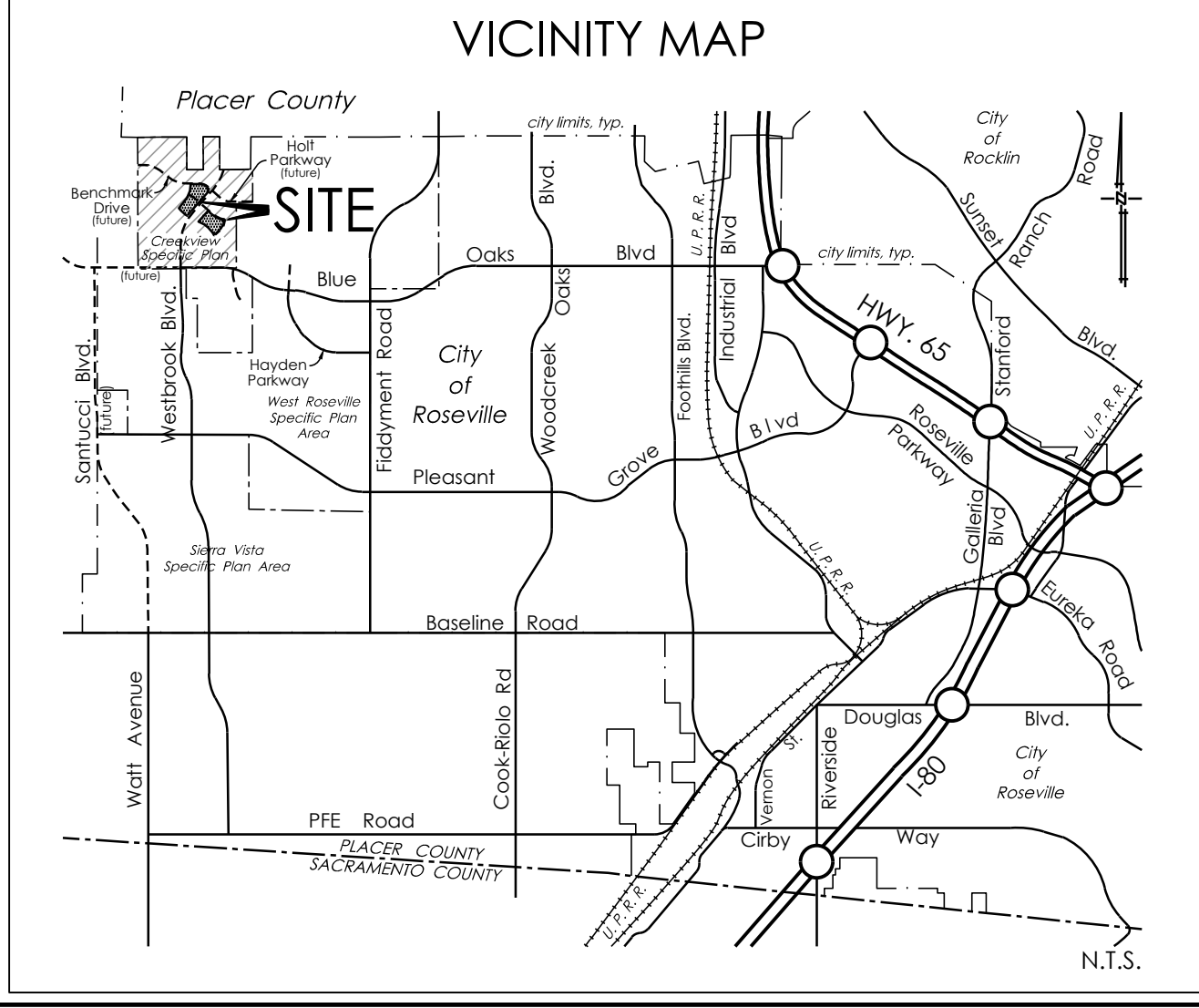

### TENTATIVE MAP INFORMATION

<b>APPLICANT:</b>	Anthem United Creekview Developments Limited Partnership 3001 Douglas Boulevard, Suite 200 Roseville, CA 95661
<b>ENGINEER:</b>	MacKay & Samps Civil Engineers, Inc. 1025 Creekside Ridge Drive, Suite 150 Roseville, CA 95678 916-773-1189
<b>SITE ADDRESS:</b>	3441, 3442 & 3575 Westbrook Boulevard Roseville, CA 95747
<b>ASSESSOR'S PARCEL NUMBER:</b>	017-101-012-.050-.051-.052 & .053
<b>SITE AREA:</b>	29.79 ± AC.
<b>GENERAL PLAN LAND USE:</b>	Existing: MDR & OS (Paseo) Proposed: MDR & OS (Paseo)
<b>ZONING:</b>	Existing: RS/OS & OS Proposed: RS/OS & OS
<b>NUMBER OF LOTS/PARCELS:</b>	249 TOTAL LOTS 234 MDR Residential Lots 4 OS Paseo Lots 2 ROW/Landscape Corridor Lots 7 Landscape Lots
<b>SERVICE PROVIDERS:</b>	Parks & Recreation: City of Roseville Police & Fire Protection: City of Roseville Sanitary Sewer: City of Roseville Potable & Recycled Water: City of Roseville Electricity: City of Roseville Telephone: Consolidated Communications Gas: PG&E Cable: Comcast/Consolidated Communications Storm Drainage: City of Roseville Schools: Roseville City School District Roseville Joint Union High School District



### PARCEL SUMMARY

Parcel	Acres	Units	Lot Size (typ)	Parcel	Sq. Ft. (Ac.)
<b>Parcel C-20</b>				<b>Parcel C-21</b>	
C-20 Residential Lots	8.41 ac.	77 du	35' x 80'	Lot 20A (Paseo)	4,167 sf
C-20 Paseo Lots	0.70 ac.			Lot 20B (Paseo)	26,376 sf
C-20 Landscape Lots	0.16 ac.			Lot 20C (Landscape)	5,444 sf
subtotal	9.27 ac.			Lot 20D (Landscape)	1,378 sf
<b>Parcel C-21</b>				Lot 21A (Landscape)	5,030 sf
C-21 Residential Lots	8.23 ac.	77 du	35' x 80'	Lot 21B (Landscape)	1,421 sf
C-21 Paseo Lots	0.23 ac.			Lot 21C (Landscape)	4,421 sf
subtotal	8.49 ac.			Lot 21A (Paseo)	20,863 sf
<b>Parcel C-22</b>				Lot 22C (Landscape)	2,940 sf
C-22 Residential Lots	9.89 ac.	82 du	45' x 80'	Lot 22D (Landscape)	834 sf
C-22 Paseo Lots	1.10 ac.			subtotal	97,021.7 sf (2.23 ac.)
C-22 Landscape Lots	0.02 ac.				
subtotal	11.01 ac.	236 du			
<b>Landscape Corridor Lots (Right of Way)</b>					
LC-1 (Landscape Corridor)	0.48 ac.				
LC-2 (Landscape Corridor)	0.55 ac.				
subtotal	1.03 ac.				
<b>TOTAL</b>	<b>29.79 ac.</b>	<b>236 du</b>			

### TENTATIVE MAP NOTES

- PROPERTY DESCRIPTION: All that real property situated in the County of Placer, State of California, being a portion of Section 14, Township 11 North, Range 5 East, M.D.B.M., Lot dimensions and acreages are approximate and are subject to change.
- Lot lines and lot areas may be adjusted at the time of Final Map(s) preparation provided no additional lots are created, subject to approval by the City of Roseville. Flexibility in Large Lot parcel configuration and phasing as shown hereon is permitted with the Final Map provided that the configuration is in substantial compliance with this Phased Tentative Subdivision Map, subject to approval by the City of Roseville.
- The Final Mapping and subsequent development of parcels and streets may be phased. Project improvements are deferred to individual Small Lot Final Maps or project development plans.
- Pursuant to Government Code Section 64463.1, the subdivider may file multiple Final Maps based upon this Phased Tentative Subdivision Map. The filing of a Final Map on a portion of this Phased Tentative Subdivision Map shall not invalidate any part of this Phased Tentative Subdivision Map.
- The Final Mapping and subsequent development of parcels and streets may be phased. Phasing is to be consistent with the performance criteria in the Development Agreement and applicable infrastructure phasing matrix.
- Additional easements to accommodate new public utility improvements, access required for parcel development, rights to construct, or other similar mapping requirements needed to accomplish the final design may be added prior to each Small Lot Final Map based on this Phased Tentative Subdivision Map.
- Portions of Westbrook Boulevard (from the southerly boundary of Parcel C-21 to Benchmark Drive), Benchmark Drive (from Westbrook Blvd. to the western boundary of Parcel C-20), Creekpark Drive (from the western boundary of Parcels C-20 and C-21 to Claycreek Drive), and Claycreek Drive (from Creekpark Drive to the southerly boundary of Parcel C-22), as depicted on this Phased Tentative Subdivision Map, shall be offered as IOD(s) to the City of Roseville with the corresponding phase at the time of each Final Map. (Refer to infrastructure phasing matrix for phasing of improvements.)
- Street sections are per the Creekview Specific Plan (Chapter 6) and the Creekview Design Guidelines (Appendix B), except as modified hereon.
- A minimum 12.5' Public Utility Easement (PUE) will be located adjacent to all rights-of-way unless otherwise noted.
- Landscape corridor widths may be reduced for ancillary right-turn lanes, auxiliary lanes, bus turn-outs, standard tapers, and the like per the provisions in the Creekview Specific Plan.
- Paseo lots are to be dedicated as street rights-of-way (ROW).
- The following lots are to be offered to the City of Roseville with the corresponding phase at the time of each Final Map: OS (Paseo) Lots 20A, 20B, 22A & 22B, ROW Lots C-2 & C-2, and Landscape Lots 20C, 20D, 21A, 21B, 21C, 22C & 22D.
- Construction of masonry walls and fencing is to be consistent with the Creekview Design Guidelines (Appendix B), except as modified hereon.
- The design and placement of entry signage and monuments is to be consistent with the previous phases of the Creekview project.
- Landscape corridor lots, paseo lots, and landscape lots are not to be counted as "lots" towards any future boundary line adjustment.

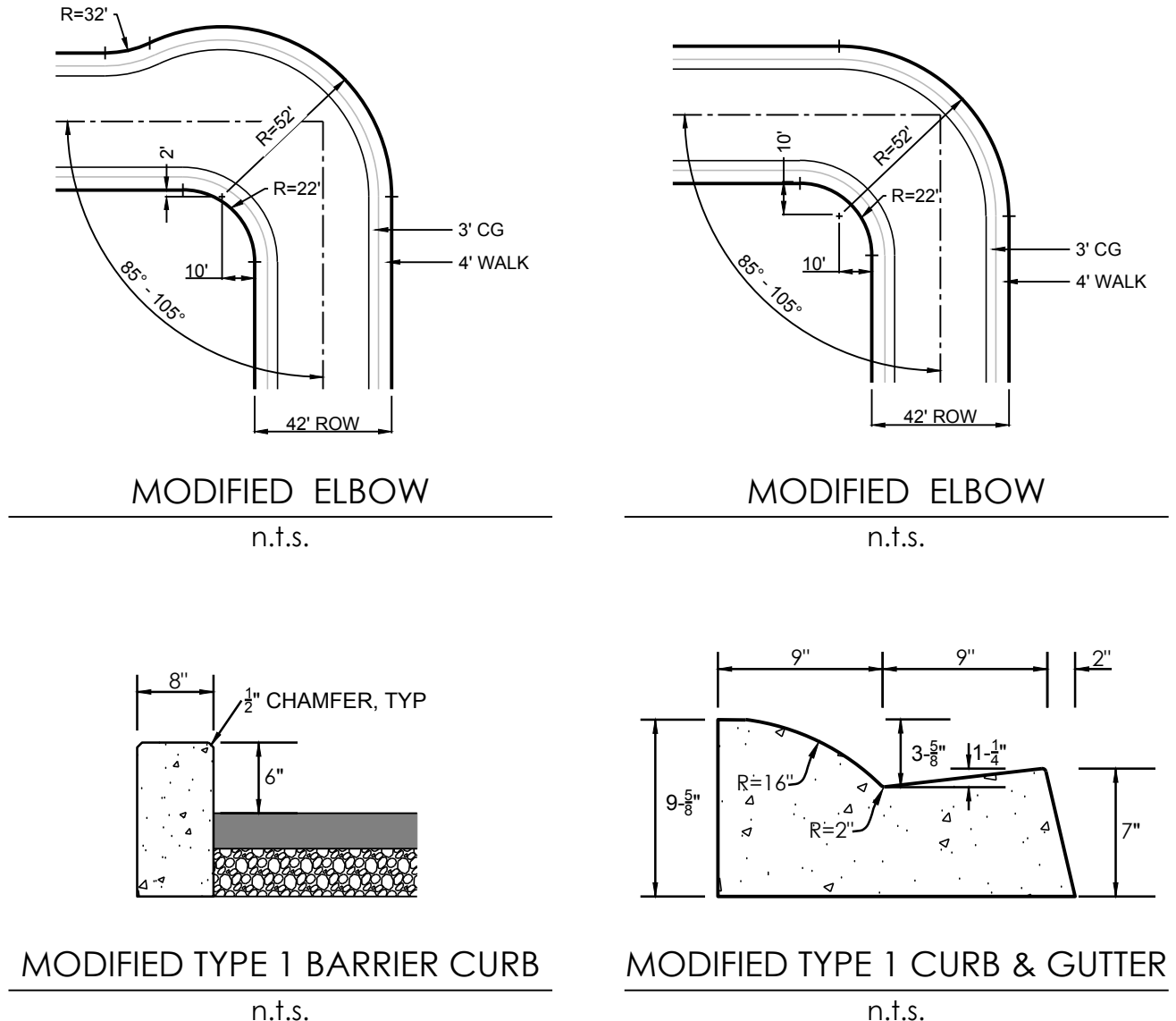

### ABBREVIATION KEY

PUE	Public Utility Easement
LS	Landscape Lot
LC	Landscape Corridor Lot
LSE	Landscape Easement
ROW	Right of Way
CG	Curb and Gutter
ℓ	Property Line

### ESTIMATED EARTHWORK SUMMARY\*

CUT:	59,400 c.y.
FILL:	71,400 c.y.
NET:	12,000 c.y.

\* See Attachment A, Mass Haul Diagram

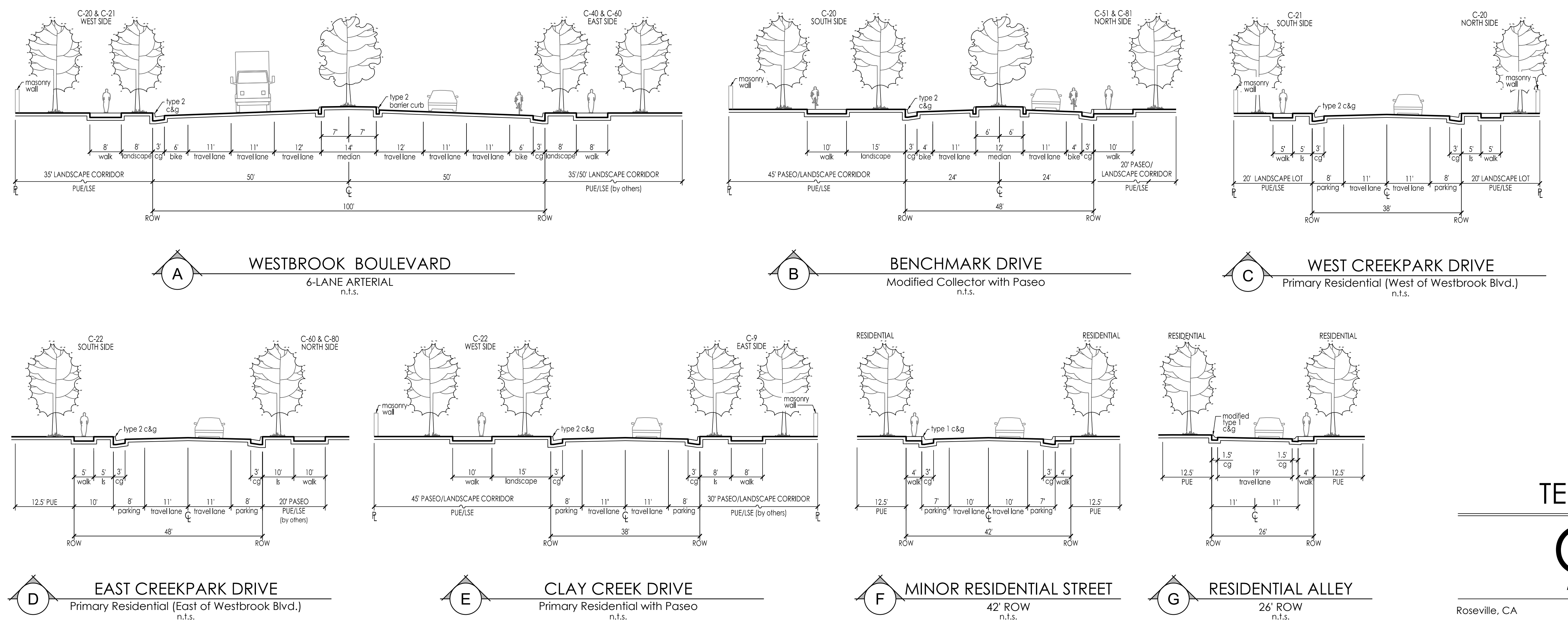

COVER SHEET  
TENTATIVE SUBDIVISION MAP

# CREEKVIEW

Parcels C-20, C-21 & C-22 of the Creekview Specific Plan











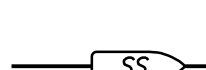

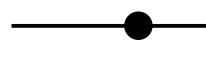
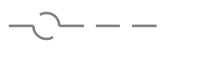
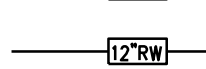

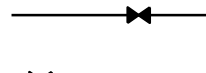

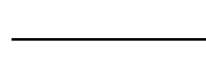



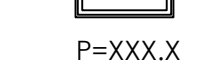

Roseville, CA

**MACKEY & SAMPS**  
ENGINEERS PLANNERS SURVEYORS

November 25, 2020

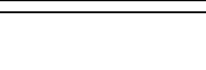
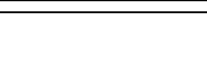
Sheet 1 of 5

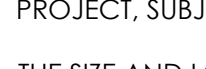

PROPOSED	DESCRIPTION	EXISTING
	SANITARY SEWER PIPE	
	SANITARY SEWER MANHOLE	
	WATER LINE	
	RECYCLED WATER LINE	
	GATE VALVE	
	FIRE HYDRANT	
	BLOW-OFF VALVE	
	STORM DRAIN PIPE	
	STORM DRAIN MANHOLE	
	DROP INLET	
	STORMWATER FACILITY	
	PAD GRADE	
	OVERLAND RELEASE FOR DRAINAGE	

- UTILITY NOTES**
1. ALL EXISTING UTILITY LOCATIONS SHOWN ARE APPROXIMATE.
  2. UTILITIES MAY BE PHASED DEPENDING UPON THE DEVELOPMENT SEQUENCE OF THE PROJECT, SUBJECT TO THE REVIEW OF THE CITY OF ROSEVILLE.
  3. THE SIZE AND LOCATION OF PROPOSED WATER, RECYCLED WATER, SEWER, AND STORM DRAINAGE INFRASTRUCTURE IS SUBJECT TO CHANGE DURING FINAL DESIGN, SUBJECT TO REVIEW AND APPROVAL BY THE CITY OF ROSEVILLE WITH IMPROVEMENT PLANS.
  4. ANY OFFSITE GRADING SHALL REQUIRE RIGHT OF ENTRY FROM ADJOINING PROPERTY OWNERS. IF A RIGHT OF ENTRY CANNOT BE OBTAINED, RETAINING WALLS ALONG PROPERTY LINES ARE TO BE CONSTRUCTED.

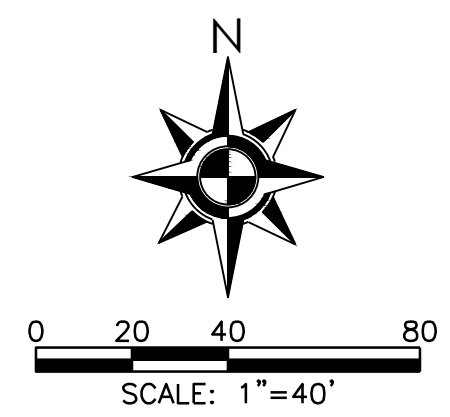
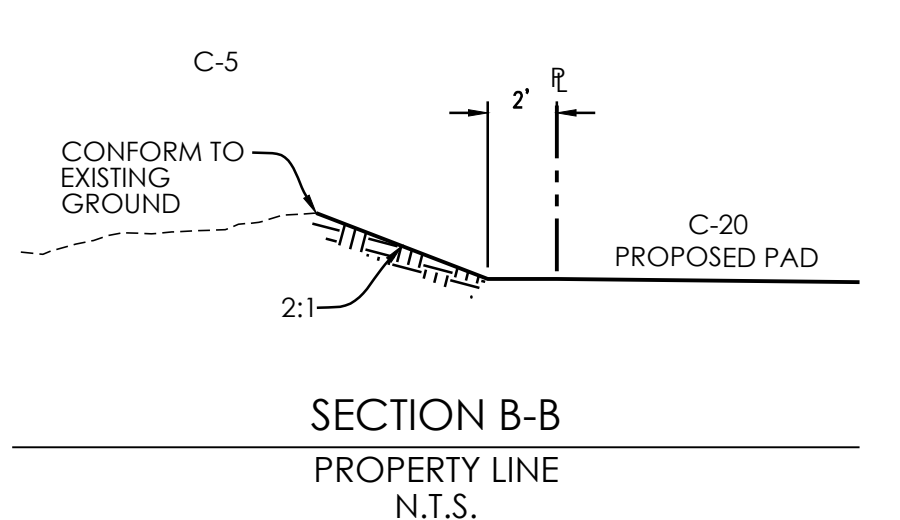
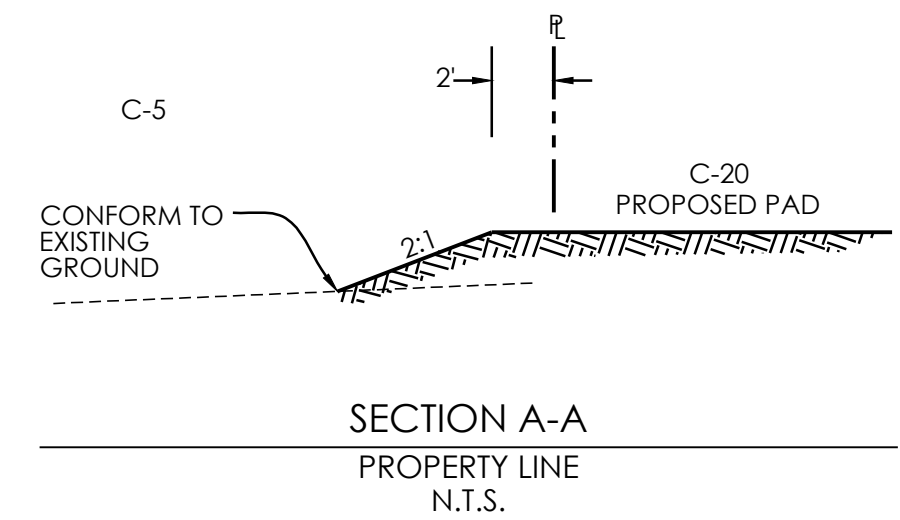

GRADING, DRAINAGE & UTILITIES  
TENTATIVE SUBDIVISION MAP

# CREEKVIEW

Parcels C-20, C-21 & C-22 of the Creekview Specific Plan

Roseville, CA

**MACKEY & SOMPS**  
ENGINEERS PLANNERS SURVEYORS

November 25, 2020

Sheet 2 of 5

Creekview MDR SETW 18431 MDR SETW



PROPOSED	DESCRIPTION	EXISTING
	SANITARY SEWER PIPE	
	SANITARY SEWER MANHOLE	
	WATER LINE	
	RECYCLED WATER LINE	
	GATE VALVE	
	FIRE HYDRANT	
	BLOW-OFF VALVE	
	STORM DRAIN PIPE	
	STORM DRAIN MANHOLE	
	DROP INLET	
	STORMWATER FACILITY	
	PAD GRADE	
	OVERLAND RELEASE FOR DRAINAGE	

- UTILITY NOTES**
- ALL EXISTING UTILITY LOCATIONS SHOWN ARE APPROXIMATE.
  - UTILITIES MAY BE PHASED DEPENDING UPON THE DEVELOPMENT SEQUENCE OF THE PROJECT, SUBJECT TO THE REVIEW OF THE CITY OF ROSEVILLE.
  - THE SIZE AND LOCATION OF PROPOSED WATER, RECYCLED WATER, SEWER, AND STORM DRAINAGE INFRASTRUCTURE IS SUBJECT TO CHANGE DURING FINAL DESIGN, SUBJECT TO REVIEW AND APPROVAL BY THE CITY OF ROSEVILLE WITH IMPROVEMENT PLANS.
  - ANY OFFSITE GRADING SHALL REQUIRE RIGHT OF ENTRY FROM ADJOINING PROPERTY OWNERS. IF A RIGHT OF ENTRY CANNOT BE OBTAINED, RETAINING WALLS ALONG PROPERTY LINES ARE TO BE CONSTRUCTED.

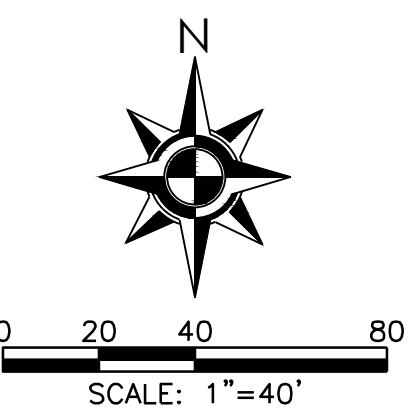
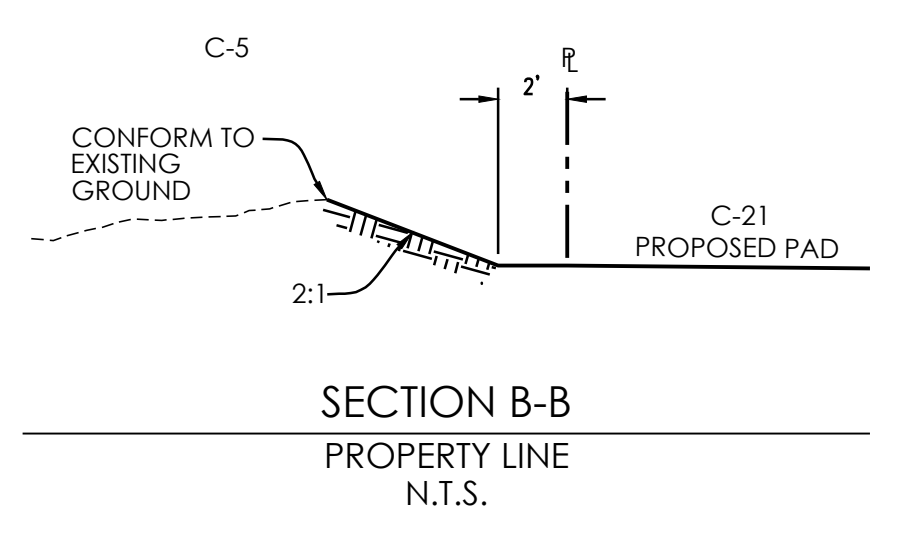
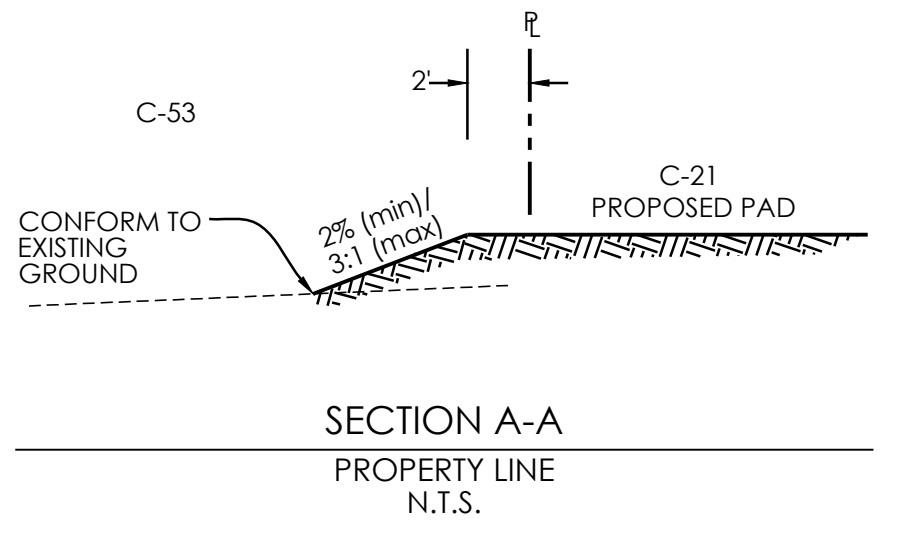

GRADING, DRAINAGE & UTILITIES  
TENTATIVE SUBDIVISION MAP

**CREEKVIEW**  
Parcels C-20, C-21 & C-22 of the Creekview Specific Plan



PROPOSED	DESCRIPTION	EXISTING
	SANITARY SEWER PIPE	
	SANITARY SEWER MANHOLE	
	WATER LINE	
	RECYCLED WATER LINE	
	GATE VALVE	
	FIRE HYDRANT	
	BLOW-OFF VALVE	
	STORM DRAIN PIPE	
	STORM DRAIN MANHOLE	
	DROP INLET	
	STORMWATER FACILITY	
	PAD GRADE	
	OVERLAND RELEASE FOR DRAINAGE	

- UTILITY NOTES**
- ALL EXISTING UTILITY LOCATIONS SHOWN ARE APPROXIMATE.
  - UTILITIES MAY BE PHASED DEPENDING UPON THE DEVELOPMENT SEQUENCE OF THE PROJECT. SUBJECT TO THE REVIEW OF THE CITY OF ROSEVILLE.
  - THE SIZE AND LOCATION OF PROPOSED WATER, RECYCLED WATER, SEWER, AND STORM DRAINAGE INFRASTRUCTURE IS SUBJECT TO CHANGE DURING FINAL DESIGN. SUBJECT TO REVIEW AND APPROVAL BY THE CITY OF ROSEVILLE WITH IMPROVEMENT PLANS.
  - ANY OFFSITE GRADING SHALL REQUIRE RIGHT OF ENTRY FROM ADJOINING PROPERTY OWNERS. IF A RIGHT OF ENTRY CANNOT BE OBTAINED, RETAINING WALLS ALONG PROPERTY LINES ARE TO BE CONSTRUCTED.

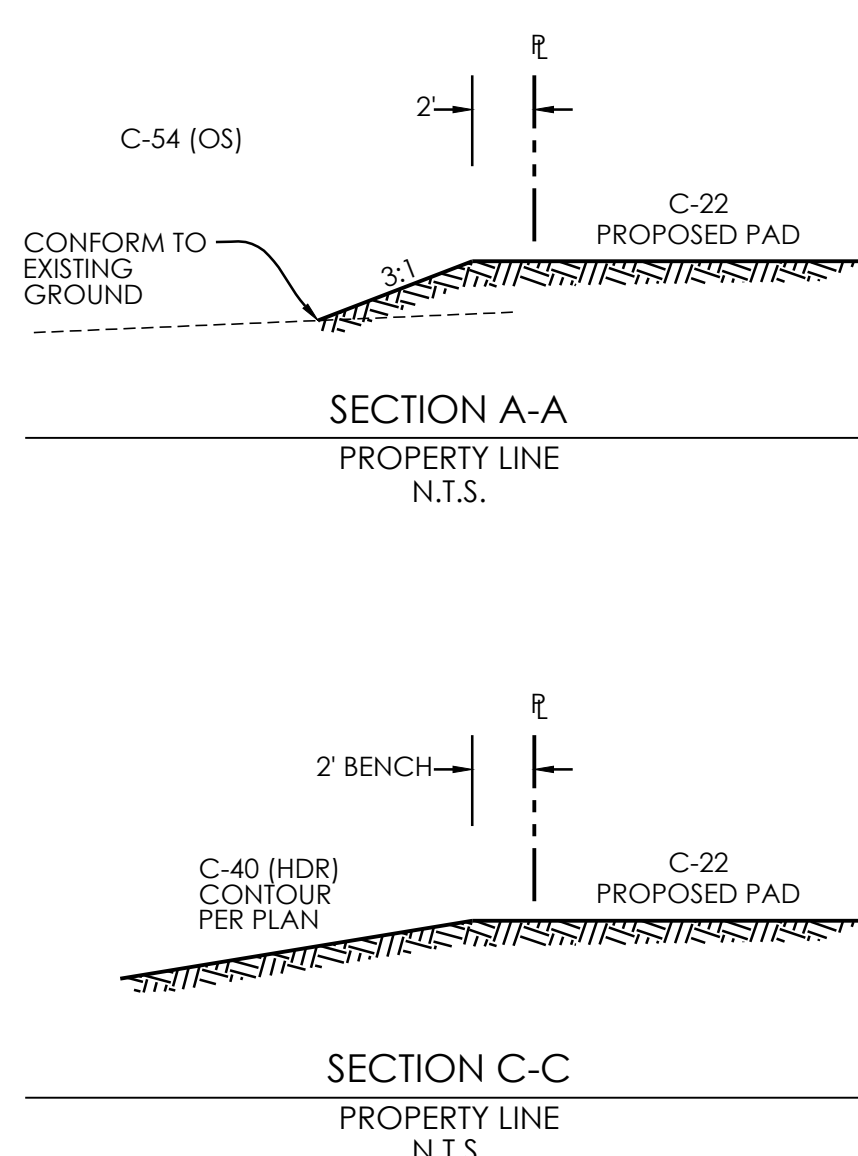

**GRADING, DRAINAGE & UTILITIES**  
**TENTATIVE SUBDIVISION MAP**

# CREEKVIEW

Parcels C-20, C-21 & C-22 of the Creekview Specific Plan

